

General Terms and Conditions of Connection and Warranty

Buffer Tank

Please pass on to the user.

Dear customer!

You have chosen a buffer tank produced by our company for water heating.

We thank you for your trust.

You will receive an elegantly designed device that was constructed in accordance with the state of the art and the applicable regulations. Continuous research as well as an ongoing quality control during the production provide our buffer tanks with technical characteristics that you will always value.

The installation and first commissioning must be performed by a licensed plumber and in accordance with these instructions only.

You will find all important information for a correct assembly and operation in this small brochure. Nevertheless, let your concessionary explain to you how the device functions and demonstrate its operation. Of course, our customer service and sales department are at your service to support you in case you need any advice.

Please read through all the information provided in these instructions carefully. Keep these instructions in a safe place and pass them on to subsequent owners, if applicable.

Enjoy the use of your buffer tank.

1. Technical data

For technical production reasons, the floor and hood designs may vary from the illustration.



**PSR/PSRR buffer tank
with heating coil**
PSR 500 - 5000l
PSRR 500 - 3000l

PSM buffer tank with 6/4" coupling sleeves
500 - 5000l

**PSF buffer tank
Flange D 240**
500 - 5000l

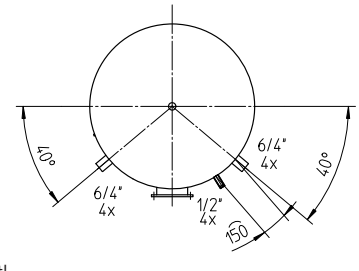
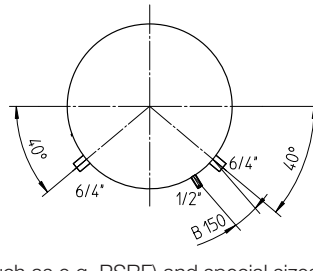
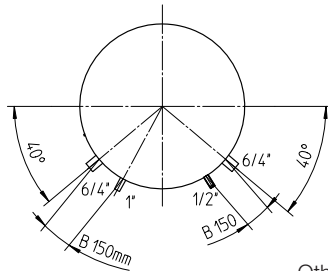
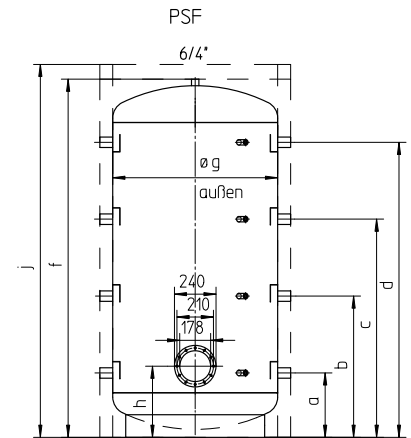
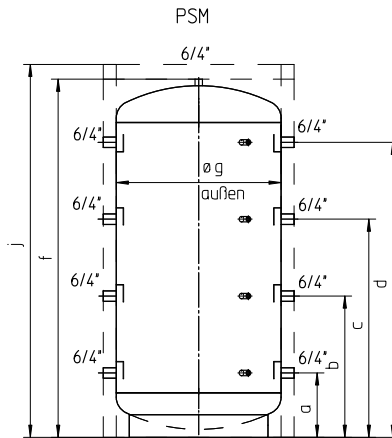
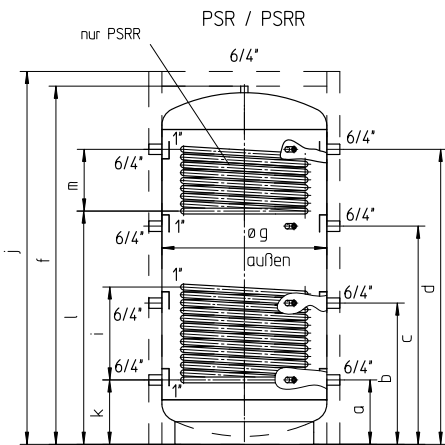

Other designs (such as e.g. PSRF) and special sizes on request!

Rated volume l	Dimensions in mm												Tipping height mm		Coil surface m ²		Coil capacity l	
	a	b	c	d	f	Øg	h	i	j	k	l	m	top	bottom	top	bottom		
500	220	620	1010	1390	1640	650	340	495	1725	220	1040	350	1670	1.2	1.8	7.5	11	
800	260	630	1030	1430	1700	790	390	585	1785	260	1070	360	1750	1.8	2.4	11	15	
1000	310	745	1250	1710	2050	790	390	720	2135	310	1160	540	2090	2.4	3.0	15	19	
1250	330	705	1105	1480	1810	1000	-	630	1900	330	-	-	1900	-	3.0	-	19	
1500	380	825	1350	1760	2150	1000	415	800	2235	375	1260	495	2270	2.4	3.6	15	22	
2000	320	900	1490	2020	2380	1100	423	800	2465	320	1419	610	2610	2.8	4.2	18	26	
3000	380	1020	1680	2330	2760	1250	470	1050	2845	380	1520	750	2950	3.0	4.2	19	26	
4000	490	1090	1840	2390	2840	1400	570	1065	2935	490	-	-	3040	-	5.0	-	31	
5000	400	1100	1810	2520	2935	1600	640	1000	3035	580	-	-	3140	-	6.0	-	37	

2. Operational Conditions and Important Information

The device is suitable exclusively for the purpose of heating water in closed rooms and must be installed by licensed experts only (under observation of the relevant standards, for example ÖNORM B2531-1; DIN 1988). Buffer tanks from AE are suitable for all hot water central heating systems, no matter whether solid fuel or oil-fired boilers, heat pump, solar plant, gas or electric circulator. In addition, multiple buffer tanks can be connected to groups. This way, the storage volume can be adjusted individually, depending on requirement. Furthermore, the buffer tanks can be used also as cold water storage for cooling processes or heat recovery in industrial plants.

The tanks must be used exclusively in accordance with the conditions specified on the rating plate under a maximum operating pressure of 3 bar.

Aside from the legally approved national regulations and standards (Austria: ÖVE, ÖNORM, etc.), the terms and conditions of connection of the local power company and water works must be complied with, as well as the mounting and operating instructions. The water heating must be performed in accordance with the applicable standards (for example: ÖNORM H 5195-1).

The room in which the device is operated must be free of frost. The mounting of the device must be performed at a location that would justifiably be taken for granted, i.e. the device must be easily accessible in the case of any necessary maintenance, repairs or possible replacement. This means that all structural installations impairing trouble-free work must be removed by the end user. In the case of an assembly, mounting and operation of the water heater at unusual locations (e.g.: attics, living quarters with floors susceptible to water, store rooms, etc.), a possible penetration of water must be taken into account, and thus a device with an appropriate drain must be provided to collect any penetrating water, in order to prevent secondary damages this way. The device must be assembled and operated in an arrangement that is in accordance with the purpose and on a level surface that is suitable for the weight of the filled water heater.

Caution: the buffer tank is not suitable for heating of drinking water!

3. Screwed Heating Element

In the case of some buffer tanks, a 1½" sleeve is installed, which can be used for the installation of an electric screw-in heating element serving for additional heating or coasting of temperature. The technical concept of screwed heating elements is designed as so-called auxiliary heating, and must not be used as permanent heating.

4. Flange Port (PSF Types)

Electric built-in heaters or heat exchangers can be mounted to the boiler flange, depending on the system design.

Electric built-in heaters must be installed in such a way that the sensor of the temperature controller is positioned at the top.

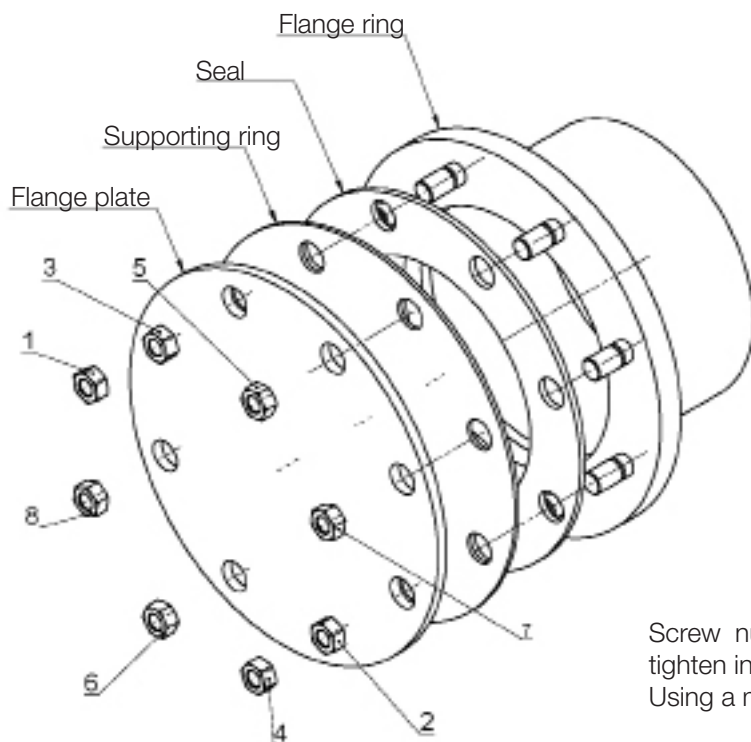

Screw nuts tight manually at first and then tighten in the order shown
Using a momentum of 20 Nm to max. 25 Nm.

5. Connection with Central Heating

The heating coil resp. the double shell must be rinsed prior to commissioning in order to remove any possible contamination (e.g. scale) from the heating circuit. The heating water must be treated in accordance with the national regulations and standards (e.g. ÖNORM H5195-1) during commissioning and comply with the regulations.

Tank with Tube Register (PSR Types)

The tube registers (heat exchangers) installed in the tank are suitable for the connection to a hot-water heating at the pressure and temperature that is indicated on the rating plate of the buffer tank. Forced circulation by means of a pump is required.

A shutoff device should be installed in the flow in the case that a buffer tank with a tube register is installed, so that backheating into the heating circuit is prevented in the case of switched off central heating and heat pumping or electric operation. However, under no circumstances must the flow and the return be shut off, as otherwise the water contained in the register cannot expand and a risk of damage to the heat exchanger exists.

The tube register must be rinsed through before being put into operation for the first time.

6. Important Mounting Information

The dimensioned sketches and any possible labels included in the packaging must be observed for mounting of the device.

CAUTION: the weight of the water heater including the weight of the water content (the nominal capacity) must be taken into account for the technical load-bearing and strength-related arrangement of the mounting surface of the device resp. for selection of the mounting location.

Distances to firing places must be taken from the Manufacturer's documentation as well as the relevant stipulations.

If a water heater is provided with enclosures (casing), installed in narrow, small rooms or in intermediate ceilings or similar, then it must bindingly be observed that the connecting block of the device (water supplies, room for electric connections resp. installation of heating) remains freely accessible and no heat accumulation is created. A free space of at least 500mm must remain for de-installation of the heating flange.

To prevent corrosion, the water in the buffer tank should not be refilled constantly.

The non-observance of these regulations represents an improper use in the case of damage, and thus the debarment from the terms and conditions of warranty.

Devices with electrically powered built-in heaters are equipped with a safety temperature limiter, which switches off further heating of the device at a temperature of max. 130°C (EN 60335-2-21; ÖVE-EW41, part 2 (500)/1971). Therefore, the selection of the connector components (connecting pipes, circulation, safety valve combination, etc.) must be planned in such a way that the connector components resist temperatures of 130°C in the case of a possible malfunction of the temperature controller, and that possible consequential damages are avoided.

Mounting and installation must be performed exclusively by authorised professionals.

The system operator must ensure that a risk to persons who are not instructed in the use of the facilities by means of scalding with hot water cannot occur.

7. Temperature Display, Temperature Control for Charge Pump

In the case that external controls are installed, it must be ensured that the boiler temperature cannot exceed 95°C during practical operation.

8. First Commissioning

The room in which the device is operated must be free of frost.

The first commissioning and heating must be monitored by an expert.

The storage tank must be filled with water before being connected to the electric grid and put into operation for the first time. The plug valve on the fitting must be opened during initial filling. The buffer tank is completely full when water exits bubble-free from the drain pipe of the fitting. All connections, also those closed on the side of the Manufacturer (flange, sleeves, etc.), must be checked for tightness during commissioning. Then check the pipelines for possible leaks and rectify these if necessary. The function of the safety unit as well as the valves between the cold water supply and the buffer tank must be checked.

After heating up, the set temperature, the actual temperature of the water taken and any possible temperature display installed should correspond approximately (after deduction of the switching hysteresis and the line losses).

The volume of the water contained in the tank changes, if it is heated.

The expansion water created in the internal boiler during the heating process must be absorbed up by an appropriate expansion vessel. Please take the size of the expansion vessel from the Manufacturer's documentation.

The independent switching off of any possible electric heating element mounted resp. of the boiler by the system must be checked.

Caution: the hot water drain pipe as well as parts of the safety fitting may become hot.

This device is not designed to be used by persons (including children) with physical, sensory or mental disabilities or lacking experience and/or lacking knowledge, unless these are supervised by a person who is responsible for their safety or have received instructions on how to use this device from any such person. Children should be supervised in order to ensure that they do not play with this device.

9. Decommissioning, Emptying

If the storage tank is taken out of operation or not used for a longer period, then it must be disconnected all-pole from the electric power grid in the case of electric heating. Turn off the lead switch or the automatic cutout.

Caution: hot water may exit during emptying!

In the case of a risk of frost, it must be observed also that not only the water in the water heater and in the hot water lines can freeze, but also in all cold water supply lines to the radiators and to the device itself. Therefore, it is advisable to empty all fittings and lines holding water (also heating circuit = register) back to the frost-safe part of the domestic water system (domestic water supply).

If the storage tank is put back into operation, then it must bindingly be observed that it is filled with water and water exits bubble-free at the fittings.

10. Check, Maintenance, Care

- a) The expansion water quantity is approx. 3.5% of the storage tank's nominal capacity when fully heated (~ 80° C).
The function of the safety valve must be checked regularly (in accordance with DIN 1988). When the safety valve test knob is lifted or turned to the position »Test«, the water must flow out of the safety valve unit into the drain funnel unobstructed.
Caution: thereby, the cold water supply and parts of the storage tank connector fittings may become hot. If the storage tank is not heated up, then no water must drip from the safety valve. If this is the case, then either the water line pressure is higher than the permissible value or the safety valve is defect. If the water line pressure is higher than permitted, then a pressure reducing valve must be used.
- b) Do not use any abrasive cleaning agents and paint thinners (such as nitro, trichlor etc.) to clean the storage tank. The best cleaning is to use a damp cloth adding a few drops of a liquid household cleaner.
- e) The bare-tube heat exchanger must be rinsed professionally before performing the initial installation (we additionally recommend the installation of a dirt filter). If the bare-tube heat exchanger is not used during operation of the storage tank (e.g. electric heating only), then the same must be filled completely using an appropriate glycol mixture, in order to prevent corrosion due to the developing condensation water. Thereby, the filled bare-tube heat exchanger must not be closed on both sides after filling (pressure expansion due to temperature).
- f) The storage tank can be used exclusively in accordance with the conditions specified on the rating plate. Aside from the approved national legal regulations and standards, the terms and conditions of connection of the local power company and water works must be complied with, as well as the mounting and operating instructions.
- g) The room in which the device is operated must be free of frost. The mounting of the device must be performed at a location that would justifiably be taken for granted, i.e. the device must be easily accessible in the case of any necessary maintenance, repairs or possible replacement.

11. Electric Connection

General Information:

The connection to the electric grid must be performed in accordance with the applicable national regulations and standards, the terms and conditions of connection of the local power company and water works, as well as the mounting and operating instructions, and must be performed exclusively by a licensed electrician. The mandatory protective measures must be implemented carefully, so that no other electrically supplied devices are affected thereby (e.g. freezer, rooms used for medical purposes, intensive livestock breeding units) in the case of a defect or failure of the water heater's power supply.

In rooms with bathtubs or showers, the device must be installed in accordance with the national laws and regulations (for example ÖVE-SEV or VDE).

The technical terms and conditions of connection of the relevant power supply company must be observed bindingly.

A residual current circuit breaker with a tripping current of $I_{\Delta N} \leq 30\text{mA}$ must be switched upstream of the electric circuit.

The device must be connected to permanently installed lines only.

An all-pole disconnecting device with at least 3mm contact clearance must be switched upstream of the device. This requirement is fulfilled e.g. by an automatic cutout.

In any case, the buffer tank must be filled with water before switching on the electrical power.

In accordance with the safety regulations, the buffer tank must be switched neutral, made safe against switching on again and checked for neutral status prior to each manipulation. Manipulations to the electric system of the device must be performed exclusively by a licensed electrician.

The electric connection must principally be performed in accordance with the circuit diagram affixed inside the heating!

12. Gewährleistung, Garantie und Produkthaftung

Warranty is made according to the legal provisions of the Republic of Austria and the EU.

1. The prerequisite for honoring of warranty terms on the part of the manufacturer (hereinafter referred to as Manufacturer) is presentation of a paid invoice for the purchase of the appliance in question, whereby the identity of the appliance including model and fabrication number must be indicated on the invoice and presented by the claim applicant. The General Terms and Conditions, Terms and Conditions of Sale and Delivery of the manufacturer shall apply exclusively.
2. The assembly, installation, wiring and startup of the appliance in question must, to the extent that this is prescribed legally or in the installation and operation guide, have been performed by an authorized electrical technician or installer who has followed all the required regulations. The hot water tank (excluding outer jacket or plastic cover) must be protected from exposure to direct sunlight to prevent discoloration of the polyurethane foam and possible cracking of plastic parts.
3. The area in which the appliance is operated must be kept from freezing. The unit must be installed in a location where it can be easily accessed for maintenance, repair and possible replacement. The costs for any necessary changes to the structural conditions (e.g. doors and passages too narrow) are not governed by the guarantee and warranty declaration and therefore shall be rejected on the side of manufacturer. When erecting, installing and operating the water heater in unusual locations (e.g. attics, interior rooms with water-sensitive floors, closets, etc.), provision must be made for possible water leakage and means provided for catching the water with a corresponding drain to avoid secondary damage in the context of product liability.
4. Warranty claims will not be honored for:
Improper transport, normal wear, intentional or negligent damage, use of force of any kind, mechanical damage or damages caused by freezing or by even one-time exceeding of the operating pressure indicated on the specification label, use of an unapproved plumbing fitting or non-functional hot water tank fitting as well as inappropriate and non-functional previously used fittings. The breakage of glass and plastic parts, possible colour differences, damages caused by improper use, in particular as a result of a failure to observe the information stated in the assembly and operating instructions (Operating and Installation Instructions), damages due to external influences, connection to the wrong voltage, corrosion damage as a consequence of aggressive waters – water not suitable for use as drinking water – in accordance with the national regulations (e.g. the Austrian Drinking Water Regulation TWV – Federal Law Gazette II no. 304/2001). Deviations between the actual drinking water temperature at the tank fitting and the specified hot water temperature of up to 10°K (hysteresis of the controller and possible cooling-off due to pipelines), natural formation of boiler scale, lack of water, fire, flood, lightning, overvoltage, power failure or other types of force majeure. Use of non-original and company-external components such as e.g. heating elements, reactive anode, thermostat, thermometer, ribbed tube heat exchanger, etc. Washing-in of foreign objects or electrochemical influences (e.g. mixed installation), non-observance of the layout documents, failure to perform timely and documented replacement of the built-in sacrificial anode, lack of or improper cleaning and operation, as well as such deviations from the norm which reduce the value or functionality of the appliance even slightly. All regulations in accordance with ÖNORM B 2531 or DIN 1988 (EN 806) or the corresponding national regulations and laws must also be followed.
5. A justified claim must be reported to the closest customer service location of the manufacturer. The latter reserves the right to replace or repair a defective part or to decide whether a defective appliance shall be replaced with a working one of equal value. The manufacturer furthermore expressly reserves the right to require that the purchaser return the appliance in question.
6. Repairs made under warranty are to be performed only by persons authorized by the manufacturer. Replaced parts become the property of the manufacturer. If any repairs to the water heater become necessary as part of necessary service work, these are charged at the cost of repair and prorated material cost.
7. Any work performed without our express order, even this is done by an authorized installer, will void the warranty. Assumption of the costs for repairs performed by third parties presumes that the manufacturer was requested to eliminate the defect and did not or did not in timely fashion meet his obligation for replacement or repair.
8. The warranty period will not be renewed or extended as a result of a guarantee and warranty claim, service or maintenance work.
9. Transport damage will only be inspected and if appropriate recognized if it has been reported in writing to the manufacturer no later than the weekday following delivery.
10. Claims exceeding the terms of the warranty, in particular those for damage and consequential damages, are precluded insofar as these are legally permissible. Pro rata work times for repairs as well as the costs for restoring the equipment to its original condition must be paid in full by the purchaser. The guarantee provided extends according to this guarantee declaration only to the repair or replacement of the appliance. The provisions of the Terms of Sales and Delivery of the manufacturer remain, insofar as they are not altered by these guarantee conditions, fully in effect.
11. There is a charge for services provided outside of the context of these guarantee conditions.
12. In order for a warranty claim to be honored by the manufacturer, the appliance must be paid for in full to the manufacturer and the claimant must have met all his obligations to his vendor in full.
13. The enameled internal boiler for water heaters is warranted additionally for a period of 5 years following the delivery date as long as the warranty terms described under 1 to 11 above have been satisfied. If the warranty terms have not been met, the legal warranty requirements of the respective country from which the appliance was shipped shall prevail
14. Claim satisfaction according to prevailing Austrian Product Liability Law:
Claims for compensation under the title of product liability are only justified if all prescribed measures and necessities for fault-free and approved operation of the appliance have been met. This includes among other things the prescribed and documented anode replacement, connection to proper operating voltage, prevention of damage due to improper use, etc. From these conditions it can be concluded that if all requirements are met (norms, installation and operation guide, general guidelines, etc.), the device or product fault resulting in the secondary damages would not have occurred. Furthermore it is mandatory that for processing of the claim the necessary documentation such as the part number and manufacturing number of the water heater, the seller's invoice and that of the executing license holder as well as a description of the malfunction for a laboratory study of the appliance in question (absolutely required, since a specialist will study the appliance and analyze the cause of failure) be provided. To prevent misidentification of the water heater during transport, it must be marked with a highly visible and legible marking (preferably including address and signature of the end customer). Corresponding pictorial documentation indicating the extent of the damage, the installation (cold water line, hot water outlet, heating outgoing and return, safety fixtures, expansion tank if present) as well as the defect location on the water heater is also required. Furthermore the manufacturer reserves the express right to require that the purchaser provide all the documents and equipment and equipment parts necessary for clarification. The prerequisite for performing services under the title of product liability is that it is the claimant's obligation to prove that the damage was caused by the manufacturer's product. Damage compensation according to the Austrian Product Liability Law is subject to a 500 Euro deductible. Until the entire matter is clarified and the circumstances as well as determination of the causal factors are established, the manufacturer is held faultless. Non-observance of the operating and installation guide and/or the relevant norms is considered negligent and will result in a liability disclaimer within the scope of compensation for damages.

The illustrations and data are not binding and may be modified without notice when technical improvements are made.
Subject to printing errors and technical changes.